

PRINTER SPECIFICATIONS

METAL X

The Metal X is the world's first Atomic Diffusion Additive Manufacturing (ADAM) machine. It's up to 10x less expensive than alternative metal additive manufacturing technologies — and up to a 100x less than traditional fabrication technologies like machining or casting. Affordable, reliable, and easy to use, the Metal X print system gives you everything you need to go from design to fully functional metal parts faster than ever before.

PRINTER PROPERTIES	Process	Atomic Diffusion Additive Manufacturing (ADAM)
	Build Volume	300 x 220 x 180 mm (11.8 x 8.7 x 7.1 in)
	Machine Size	575 x 467 x 1120 mm (22.7 x 18.4 x 44.1 in), 75 kg (160 lbs)
	Print Chamber	Heated
	Print Bed	Heated, Vacuum Sealed Print Sheet, Auto Bed Leveling
	Print System	2 Nozzles — Metal Material and Support Release
	Power Requirements	100-240VAC, 2400W (20A peak), IEC60320 Type C20
PART PROPERTIES	Max Part Size	250 x 183 x 150 mm (9.8 x 7.2 x 5.9 in), 10kg
	Supports	Same Material with Ceramic Release Layer
	Resolution	50 micron - 200 micron
SOFTWARE	Supplied Software	Cloud Storage, Local Storage, or On-Premise (\$5,000 added fee)
	Security	Two Factor Auth, Org Admin Access, Single Sign On
MATERIALS	Launch Material	17-4 PH Stainless Steel
	Beta Materials	Tool Steel (H13, A2, D2) Titanium Ti6Al4V, Inconel (IN) 625, Copper, Aluminum (6061, 7075)
	Media (Spools)	Filament Fed, Bound Powder

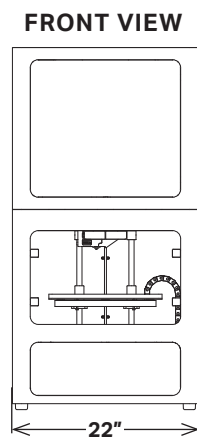
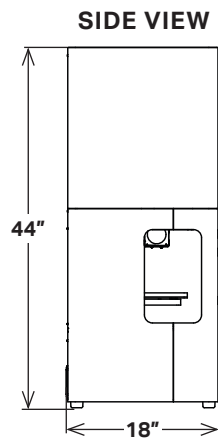

All specifications approximate and subject to change without notice.

DEBINDER SPECIFICATIONS

WASH-1

The first step in transforming a printed “green” part into fully dense metal is debinding. The Wash-1 immerses the green part in a specialized fluid which removes the primary binding material, leaving the part semi-porous so the remaining binder can easily burn off during sintering. This debinding step purifies the final metal part and helps keep your sintering furnace clean.

DEBINDER PROPERTIES	Materials Supported	All Metals
	Fluid	Opteon Sion
	Controller	Integrated Control System
	Workholding	Stainless Steel Basket
	Washing Size	356 x 254 x 203 mm (14 x 10 x 8 in)
	Washing Volume	18,356 cubic cm (1120 cubic in)
SAFETY & INSTALLATION	Environmental Req.	External Exhaust
	Safety Control	Low Fluid Shutoff Control High Vapor Pressure Shutoff Control
	Regulatory	Refer to MSDS
	Emissions	Low Emission Design to Conserve Solvent
	Power	120/240 VAC Single Phase, 15A/1650W Peak Draw
PHYSICAL DIMENSIONS	External Dimensions	609 x 685 x 1067 mm (24 x 27 x 42 in)
	Weight	136 kg (300 lbs)

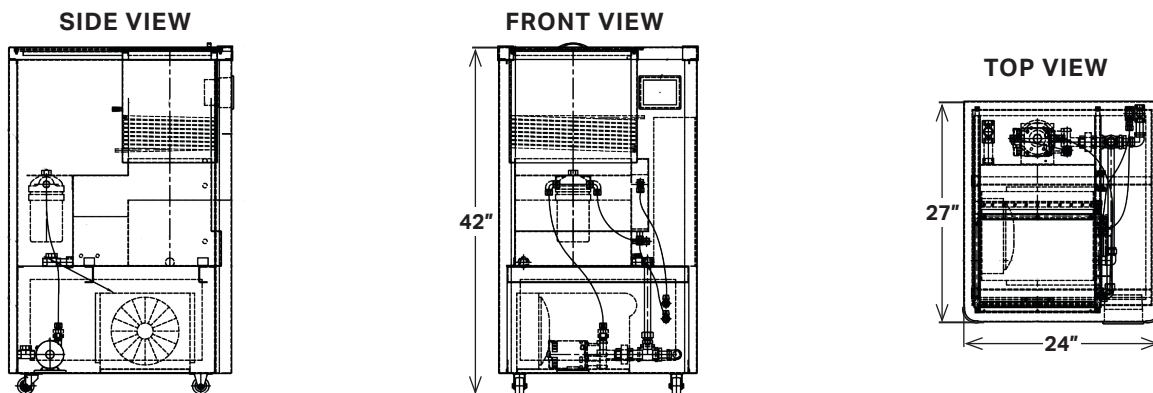

All specifications approximate and subject to change without notice.

FURNACE SPECIFICATIONS

SINTER-1

The Markforged Sinter-1 is a high performing, high value furnace - it's affordable, sizable, and reliable. Featuring 4760 cubic cm of working volume, The Sinter-1 effortlessly converts washed parts into their dense final metallic form. Built on 30 years of Metal Injection Molding (MIM) technology, it is ideal for sintering medium sized parts and small batch production.

FURNACE PROPERTIES	Materials Supported	All Commercial Grade Metals Including: Stainless Steel, Tool Steel, Inconel, Aluminum, & Titanium
	Heating Element	Kanthal
	Controller	Pre-Programmed Automatic Cycling
	Peak Temperature	1300° C
	Sintering Capacity	Cylindrical - 141 mm ID x 305 mm L (5.55" ID x 12" L)
	Sintering Volume	4760 cubic cm (290 cubic in)
	Gas Types	Nitrogen, Argon, and Forming Gases
	Retort	High Purity Refractory Retort (Carbon Free)
	Sintering Surface	Ceramic
SAFETY & INSTALLATION	Environmental Req.	External Exhaust (100 CFM)
	Power	208-250 V Single Phase 36A, Recommend Wiring 50A
	Over Temperature	Protection System Included
PHYSICAL DIMENSIONS	External Dimensions	1067 x 505 x 720 mm (42 x 20 x 28 in)
	Weight	136 kg (300 lbs)

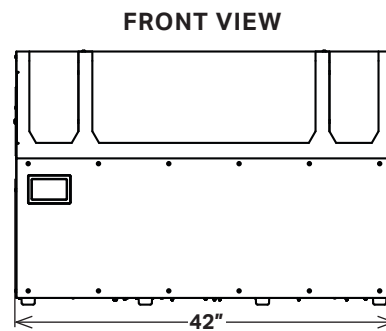
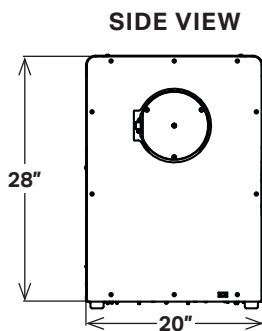

All specifications approximate and subject to change without notice.

PRODUCT SPECIFICATIONS

Sinter-2

With an expansive active hot zone (19,644 cm³ / 1,199 in³), the Sinter-2 is the perfect solution for mid-volume batch production and for larger parts. Create high-purity metal parts by using sintering technology built with a carbon-free retort. This workhorse furnace is enabled with rapid cooling technology and can process the full range of commercial-grade metals from their washed state into dense metal parts in as few as 30 hours.

Furnace Properties	Materials Supported	Chemically debound Metal X-printed parts	
	Heating Element	Kanthal	
	Controller	Pre-programmed automatic cycling	
	Sinter Run Time	30 hours*	
	Peak Internal Temp.	1,300° C / 2,372° F	
	Sintering Capacity	Rectangle w/radius top — 248 mm ID x 406 mm L (9.8 in ID x 16 in L)	
	Sintering Workload	12,135 cm ³ (741 in ³)	
	Sintering Surface Area	1,644 cm ² (254.8 in ²) for stackable ceramic setter plate	
	Setter Plate Dimensions	Top plate: 24.0cm W x 41.0cm D, (9.4in W x 16.1in D) Bottom plate: 17.0cm W x 41.0cm D, (6.7in W x 16.1in D)	
	Gas Types	Argon, argon / hydrogen mix	
	Retort	High purity refractory retort (carbon-free)	
	Safety & Installation	Environmental Req.	External exhaust (100–150 CFM)
		Power	200–240 V, 3 phase (3 wire), 30 A 346–416 V, 3 phase (4 wire), 30 A
Physical Dimensions	External Dimensions	1,200 x 700 x 1,500 mm (48 x 28 x 60 in)	
	Weight	350 kg (772 lbs)	

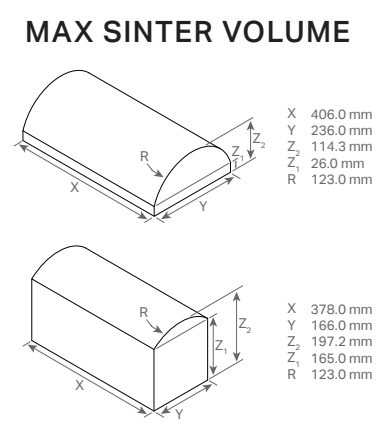
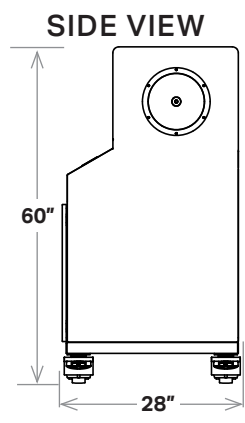
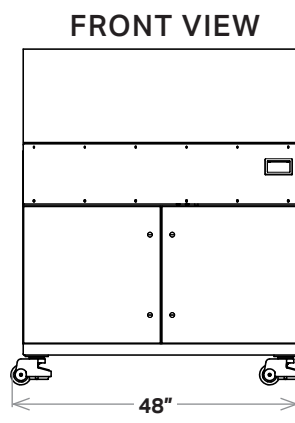

*May vary by material, operating environment, run mass, electrical frequency, etc.. **Note:** All specifications are approximate and subject to change without notice.